

35mm Fresnel lens assembling manual

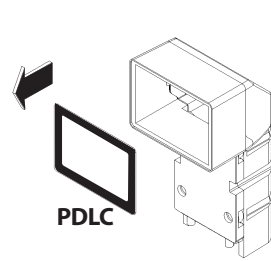

1. Carefully remove the existing **PDLC**, taking caution not to damage it. Use a thin utility knife and tweezers if necessary. Some can be easily peeled off by placing adhesive tape on top and pulling it off.

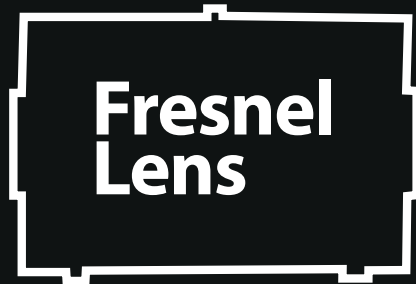
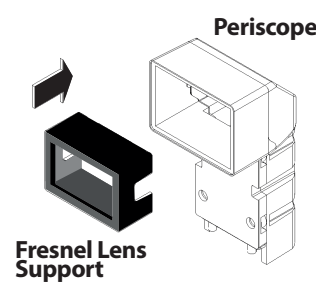

2. Insert gently the **Fresnel Lens Support** by pushing it inside the Periscope until reaching the end.
Note: do not apply too much pressure. The **Fresnel Lens Support** must be exactly **1mm** deeper than the **Internal Edge** of the I'm Back35's Periscope. In case it went deeper than **1mm** you need to pull the **Fresnel Lens Support** until reaching **1mm**.

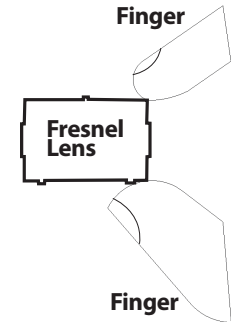
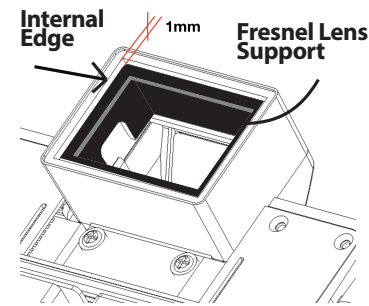

3. Identify the opaque side of the **Fresnel Lens** and pay attention not to touch the surface of it. Handle it with clean, oil-free fingers, always holding it by the edges. **Note:** we suggest the use of a rubber glove.

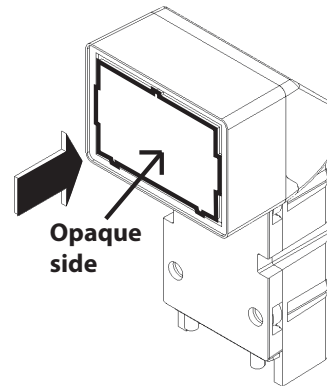

4. Place the Fresnel Lens with the opaque side externally, over the Fresnel Lens Support, check that it is perfectly aligned with the Internal Edge of the I'm Back35's Periscope.

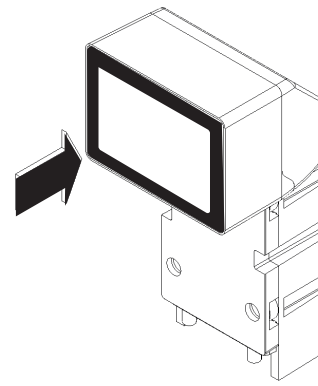

5. Place the PDLC on top of the Fresnel Lens, using the existing glue if available or adding a double-sided sticker if necessary. Ensure the PDLC is securely attached to the surface of the Fresnel Lens to avoid incorrect focus.

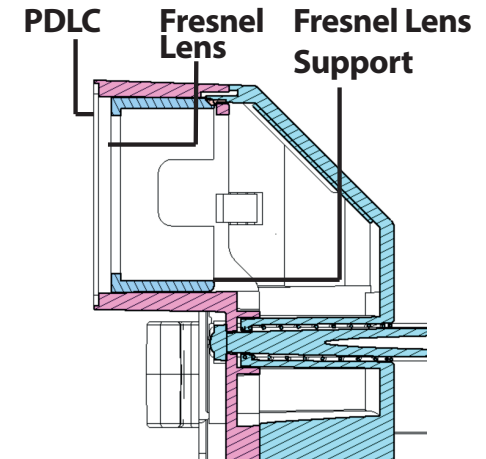

6. Diagram showing the correct layering and positioning of the components for proper alignment and focus.



I'm Back®

I'm Back Sagl
Swiss Design - Made in China
www.imback.eu



www.imback.eu
Swiss design - Made in China